



A programming model and a NoC-based architecture for streaming applications

Yun Jie Wu, Dominique Houzet, Sylvain Huet
 GIPSA-Lab, Grenoble, France
 firstname.Name@gipsa-lab.inpg.fr

Grenoble
 Images
 Parole
 Signal
 Automatique

Programming model

```
class producer1 : public sc_module {
public:
  sc_out <int> a1;
  sc_in <bool> clk;

  SC_HAS_PROCESS(producer1);

  producer1(sc_module_name name) :sc_module(name) {
    SC_THREAD(main22);
    sensitive_pos << clk;
  }

  void main22() {
    int nb1;
    nb1=1;

    while(1) {
      if ((nb1%2)==0) {
        a1.write(nb1++);
        wait();
      } else {
        a1.write(nb1);
        nb1=nb1+3;
        wait();
      }
    }
  }
};
```

Generated code from SystemC code

```
{
  int nb1;
  nb1=1;

  while(1) {
    if ((nb1%2)==0) {
      write_signal(
        F1,1,0,nb1++);
      wait(5);
    }
    else {
      write_signal(
        F1,1,0,nb1);
      nb1=nb1+3;
      wait(6);
    }
  }
}
```

Design flow

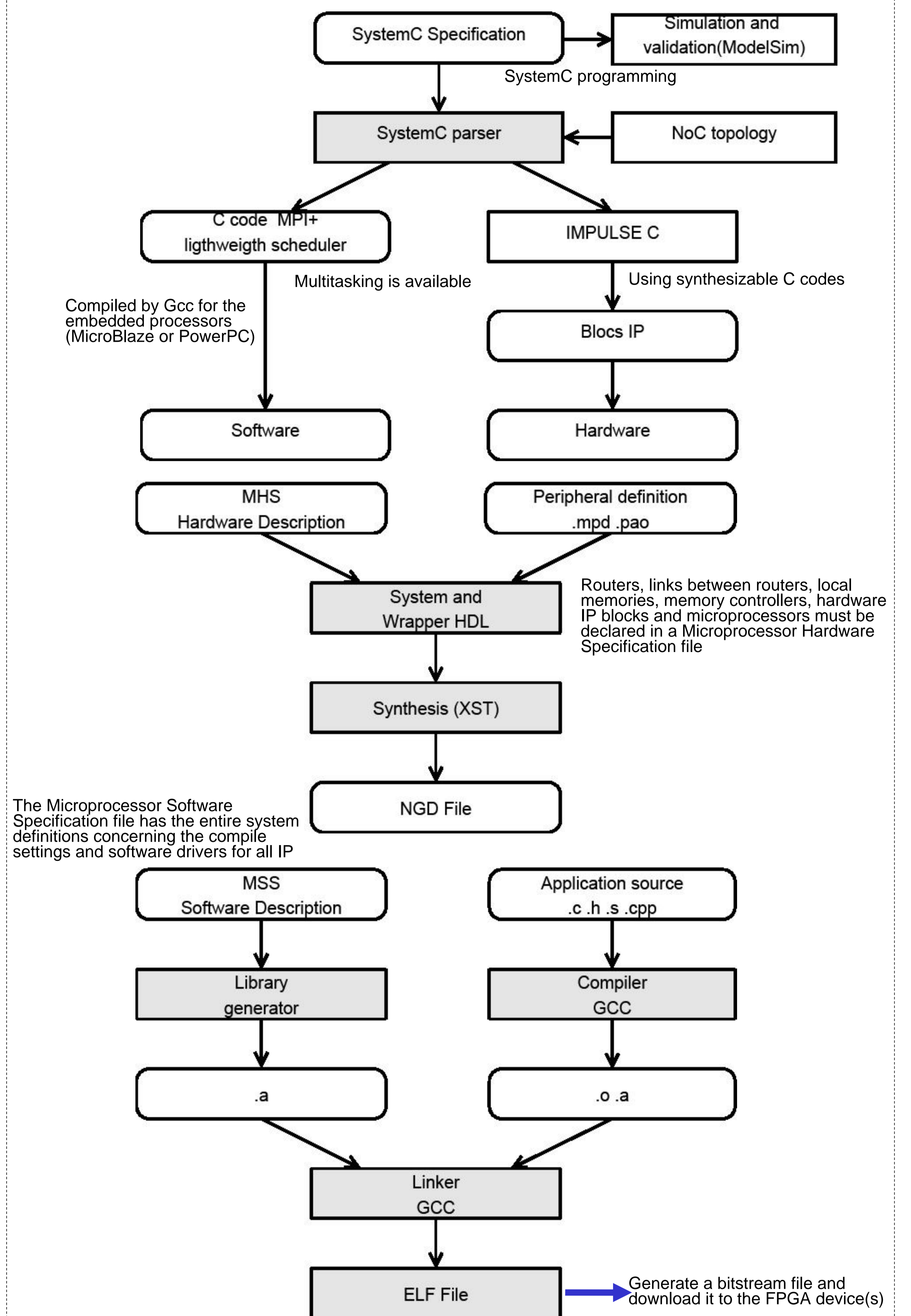

An example of NoC topology

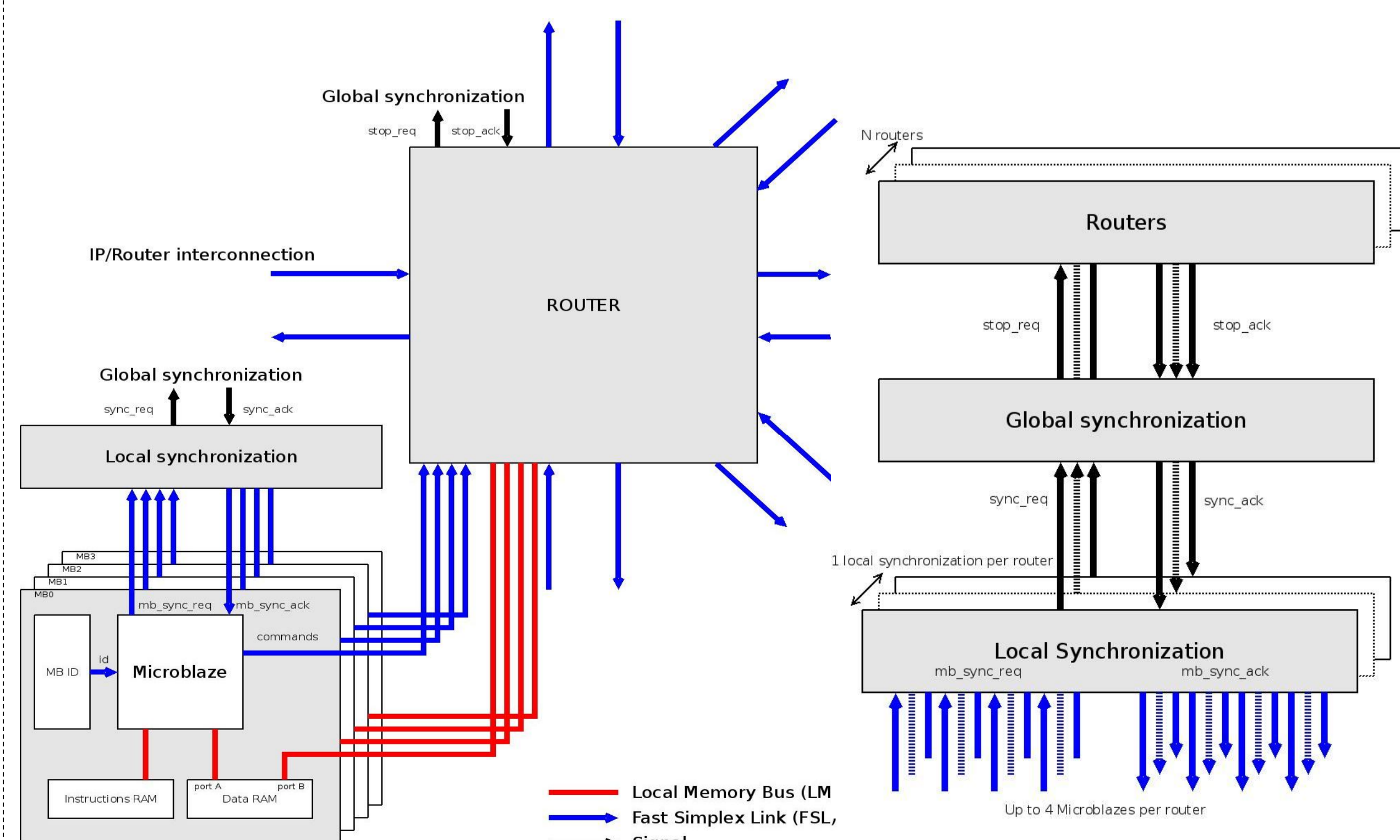
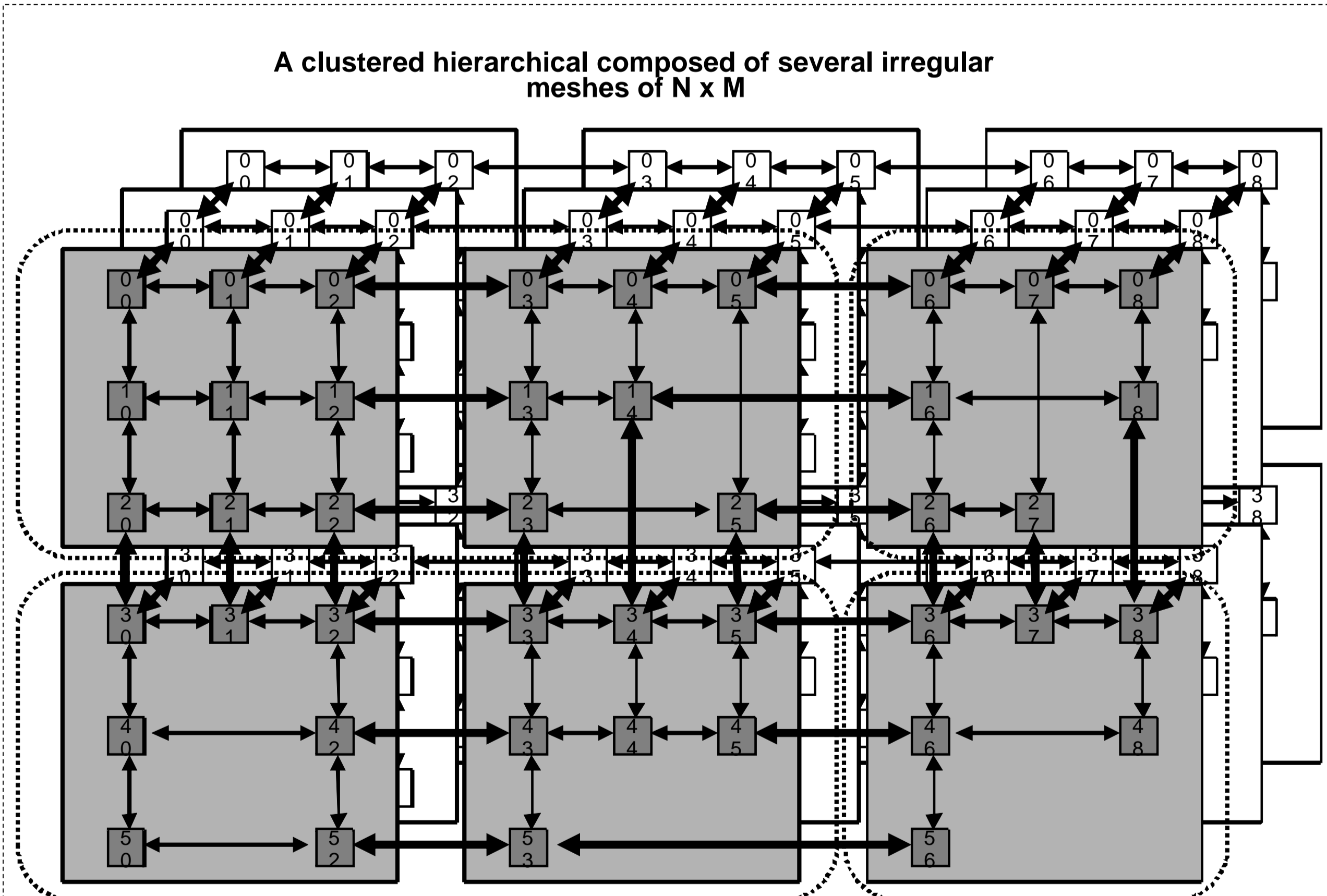

Results

Router Cost in function of the number of connected microblazes

Num. of MB	IOs	Funct. gen.	CLB Slices	DFFs or Latches	Freq. (Mhz)
1	497	2987	1494	628	173.3
2	582	3277	1639	609	178.6
4	743	3987	1994	668	203.3

The router cost is almost the cost of a MicroBlaze with the same frequency
 We can build a large SoC with tens or hundreds of processors implemented on multi-FPGAs

Timing Results in clock cycles

Timing (in clock cycles) results for the execution of the producer-consumer application for packets with 4, 8 and 16 words

Primitive	4 words	8 words	16 words
System initialization	1385	2281	4057
MPI_init()	426	426	426
MPI_Comm_Rank()	2	2	2
Scheduling (wait())	60	60	60
write_signal	86	133	175
MPI_Barrier()	2	2	2

Latency formula to compute the total time T :

$$T = (ST + (NF + 2) * TF + NH) * NP + (NP - 1)$$

- ST** = number of clock cycles to generate the header, that is 4 clock cycles
- NF** = number of flits, 16 for instance + 2 for the header and the end of packet
- TF** = 1, each flit spends one clock cycle to be transmitted to the next switch
- NH** = number of hops: each time a packet crosses a switch one clock cycle is needed
- NP** = number of packets

